

Fluid Bed Systems

Drying - Class 'A' Biosolids



Municipal Applications

Reliable Performance, Extreme Efficiency

- Class 'A' biosolids drying solution
- 90+% annual operational time is typical
- Short startup and shutdown times
- Lower material temperatures (80° to 85° C)
- Few moving parts for less maintenance
- Smart design features minimize loads on downstream processes
- Automated control accommodates varying feed moisture content making it suitable for both regional and single plants
- Typically less than 3% O₂ gas stream concentrations, resulting in inert operating conditions
- Lab testing available to characterize your material

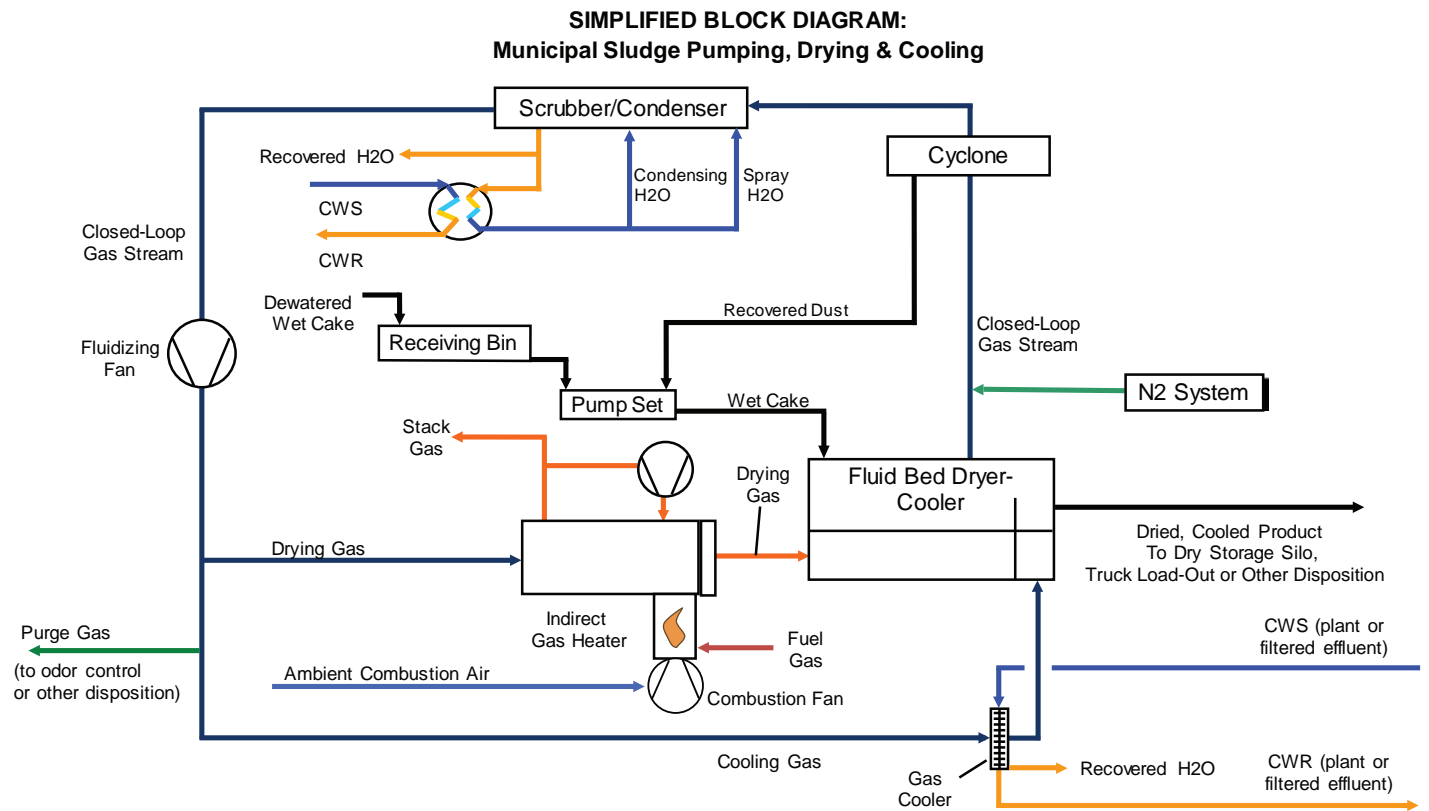

Features and Benefits

1. Collected dust is integrated with wet cake feed and directly fed into the dryer. This eliminates finished product recycling and the extra screening, milling, conveying and mixing equipment required with "add-back" or pre-conditioning steps associated with other drying technologies.
2. Closed-Loop inert fluidizing gas system provides safe equipment start-up, operating and shutdown.
3. Final product virtually free of dust.
4. Produces 1-5 mm size pellets.
5. Accommodates fluctuations in wet cake feed dry solids content without "add-back" blending or pre-conditioning the wet feed material.
6. Low maintenance with few moving parts.
7. Start-up & shutdown times of about 30 minutes or less - substantially shorter than other technologies.
8. Compact designs for retrofit applications.

Fluid Bed Drying Process

As the dewatered cake to be dried is pumped directly into the Fluid Bed Dryer, a distribution device reduces the material into smaller particles and disperses them on top of the fluidized material layer. Inside the Fluid Bed Dryer there are three primary sections:

LOWER: The lower “plenum” section houses the gas distribution plate which evenly distributes the inert fluidizing gas to actively suspend the bed of dry granules.

MIDDLE: The middle “intermediate” section houses the fluidized material that is dried to a minimum solids content of 90wt% which typically consists of particles ranging from 1 to 5 mm in diameter.

UPPER: The upper “hood” section serves two purposes. First, it provides a “disengaging space” above the fluidized layer for normal-sized particles to fall back into the product layer. Secondly, it houses the wet cake injection piping and the distribution devices.

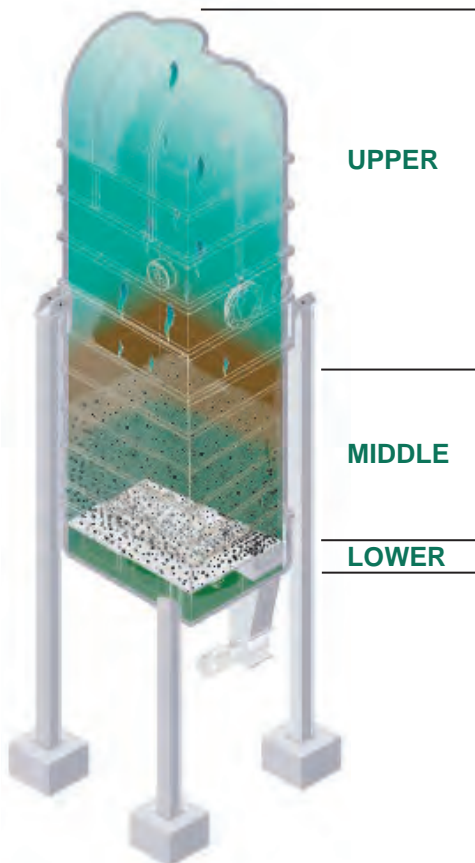

Schwing Bioaset Solutions for Water and Wastewater



Piston Pumps for Solids

High-pressure positive displacement piston pumps with lowest life cycle costs to efficiently transport biosolids through pipelines.

Class A Bioaset Process

Advanced alkaline stabilization technology that is totally enclosed and PFRP approved to operate at 55C.

Screw Press Dewatering

High-performance dewatering with low energy and maintenance requirements and the widest range of model sizes available.

Container Wagons

Evenly load containers with ground accessible service points, minimal maintenance requirements, and full automation.

Membrane Bioreactors (MBRs)

Microfiltration systems with end-free hollow fiber membranes.

Sliding Frames & Storage Silos

Truck receiving, truck loading, or intermediate storage of dewatered solids with lowest cost of ownership.

Class A Fluid Bed Drying

Thermal drying technology operating under inert conditions with high thermal efficiencies and low maintenance requirements.

Phosphorus Removal / Struvite Recovery

Remove nutrients from wastewater, improve dewatering, reduce scaling, and create a struvite end product.

Residuals Management

Offered through a partnership with our resource recovery company to transport, market, and beneficially reuse residuals.

Contact Information

Wisconsin:

350 SMC Drive
Somerset, WI 54025
TEL 715-247-3433
FAX 715-247-3438
www.schwingbioset.com

Connecticut:

TEL 203-744-2100

Florida:

TEL 239-842-6400



Printed on Recycled Paper