

## HYGROSCOPIC BULK SOLIDS

Reliable handling of bulk solids based on know-how.

Urea, NaCl, FeSO<sub>4</sub>,  
phosphates, oxalic acid,  
sugar, fertilisers, nitrates,  
and much more.

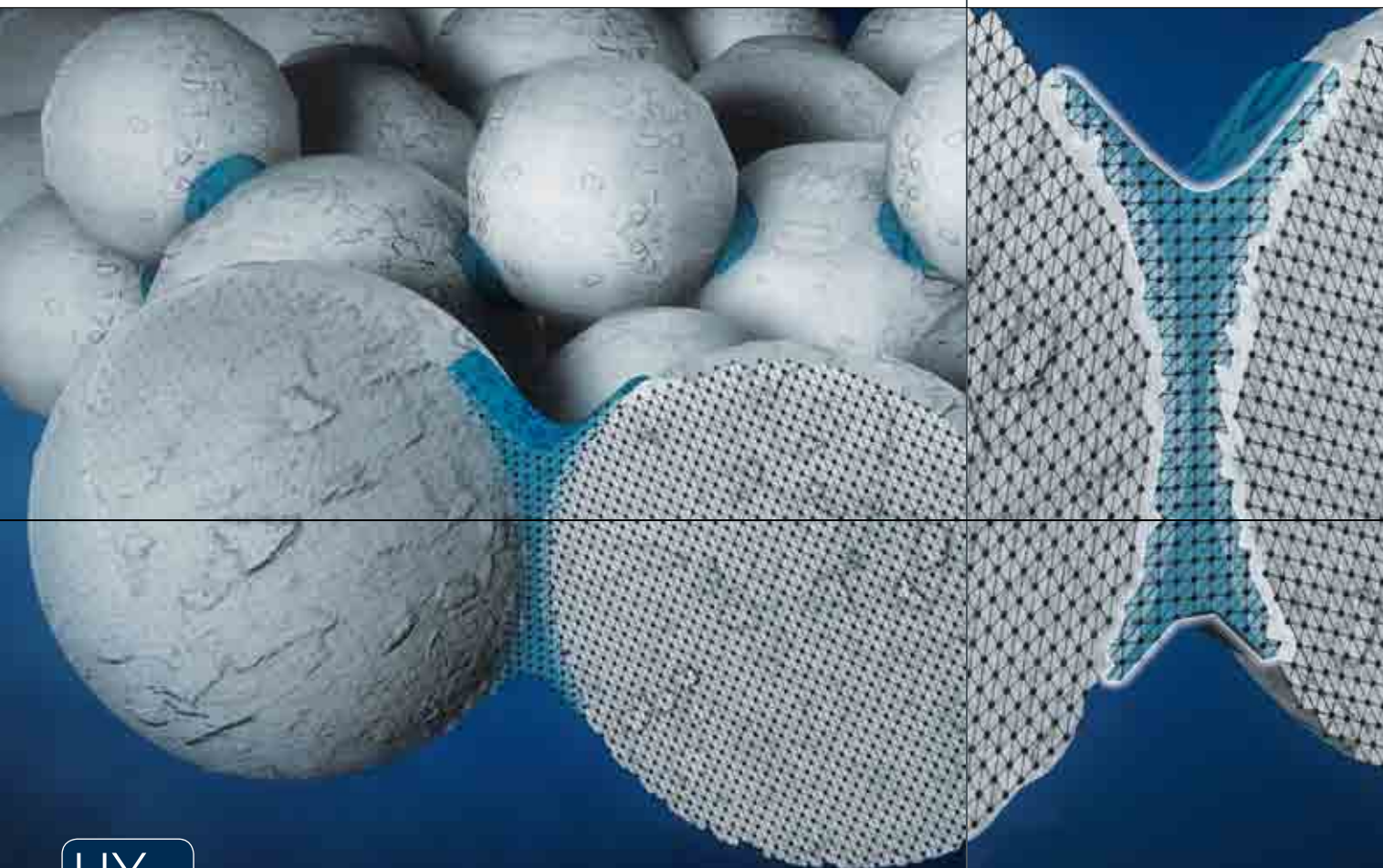

HY

hygroscopic

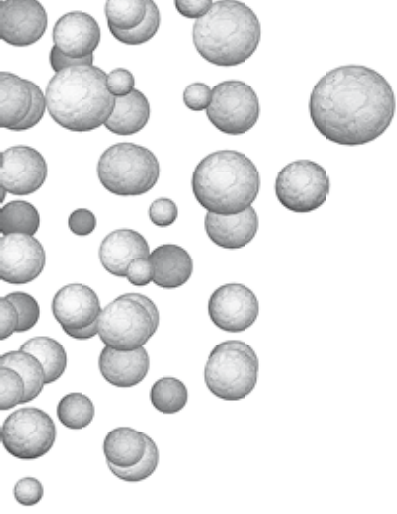

# HYGROSCOPIC MATERIALS – A QUITE SIMPLE EXPLANATION...



If through some circumstances humidity gets into your salt shaker, the salt will clump together and you won't be able to flavour your food. As a result of cooking - e.g. boiling water - steam arises and gets into the shaker. This humidity can cause bonding of the salt-crystals. To prevent the salt from clumping, a few rice grains are often placed in the salt shaker. Any moisture is absorbed by the rice grains before it infiltrates the salt.



Rice grains bond moisture before it infiltrates the salt crystals.

## ...AND OUR CORE AREA: HYGROSCOPIC BULK SOLIDS – FROM A SCIENTIFIC POINT OF VIEW.

Hygroscopic bulk solids are substances that absorb atmospheric humidity during storage and form hydrates. „Hygroscopic“ means the property of solids, to absorb, retain or emit water and to dissolve in water. Three important factors affect the ability of absorption or emission of water/humidity:



- the ambient humidity
- the temperature
- the moisture content of the bulk solid material (water quantity as a percentage of the total weight)

## THE BEHAVIOUR OF HYGROSCOPIC MATERIALS IN SILOS, BINS AND CONVEYING SYSTEMS.

On account of moisture migration, hygroscopic solids form clumps, crusts and layers in open or closed containers (silos) and also in conveying and dosing systems. The loading of subsequent processes is disturbed or in the worst case even stopped entirely.

Common measures to control the behaviour of hygroscopic bulk solids are the addition of dry air and the insulation of containers and conveying systems. In some cases, the problems can be minimized this way. In the case of highly hygroscopic substances these measures are not sufficient.



Dried solution between particles forms crystals = agglomeration!

## SUMMARY

Hygroscopic materials are very sensitive to the three parameters

1. ambient humidity, 2. temperature and 3. moisture content of the material.

If one of the three factors changes, the flow behavior of your bulk material will also change, which may affect negatively downstream processes. On the following pages you will learn more about cause and effect in relation to these three parameters, measures to control the bulk solids and, of course the latest state-of-the-art solutions.

The two main components for the efficient handling of your hygroscopic materials - **OSZILLOMAT** and **MULTIGON** - will be introduced.

In order to get an overview of hygroscopic bulk materials from various perspectives, you will also find some examples of already completed projects on pages 6 and 7.

# THE HANDLING OF HYGROSCOPIC BULK SOLIDS IS A SCIENCE OF ITS OWN. AND ALSO OUR CORE AREA.



## CAUSES OF MOISTURE MIGRATION (water exchange)

Hygroscopic bulk solids always aim to reach a moisture balance with the ambient air. Related to each temperature is a fixed ratio of ambient humidity and the moisture level of the bulk solid. In a balanced state the relationship between water content and moisture balance of bulk solids can be graphed with a curve, the so called **sorption isotherm**. Regardless of which of the factors changes, if only one of these three factors changes water exchange occurs.

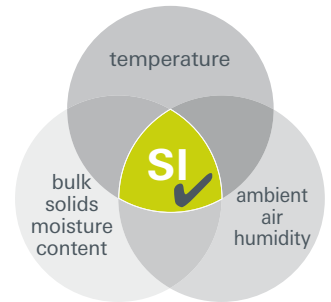
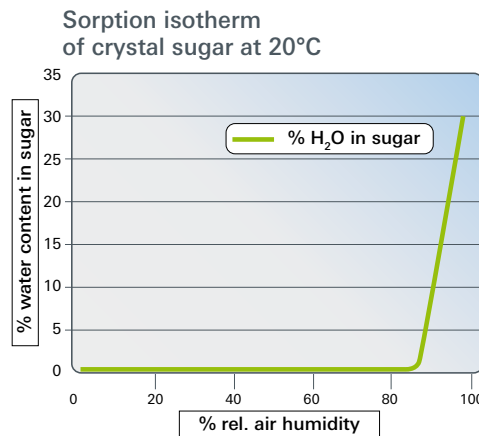

The **sorption isotherm (SI)** describes the balanced condition of the sorption of a materials surface at a constant temperature.

## THE FUSION OF BULK SOLIDS PARTICLES AS A RESULT OF WATER EXCHANGE

Due to moisture that can not be absorbed quickly enough by the particle core, the surface will fluidise. When the moisture is finally absorbed by the inside of the particles, the surface solidifies again and crystallises at its points of contact with other particles to form agglomerates. The rigidity of this connection increases.

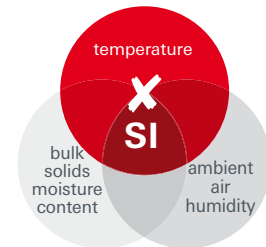

## MOISTURE MIGRATION CAUSED BY THE PRODUCTION PROCESS

After the production process the particles condition is typically hot with a wet core. Moisture and temperature between large and small particles - as well as between the particle's core and surface - are different. Adjacent lying particles with different water contents also react with each other until the balance is achieved again. This leads to agglomeration.

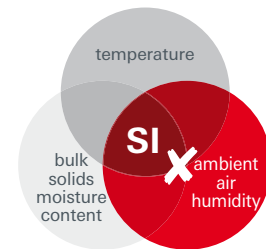

## MOISTURE MIGRATION CAUSED BY OUTSIDE INFLUENCES

If the particles are in moisture balance with each other, storage in bins and silos is easier but still bears two risks:

### AMBIENT MOISTURE

Any air that flows through silos or bins disturbs the moisture balance, whenever the amount of rel. air humidity is not equal to the bulk solids moisture level.



### AMBIENT TEMPERATURE

Any change in ambient temperature causes a change in relative air humidity in the air, that is surrounding the bulk solids. Therefore water exchange starts anew until moisture balance is once again reached.

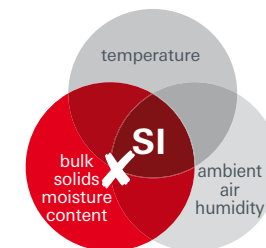

# THE THREE BASIC PARAMETERS OF THE SORPTION ISOTHERM.

## EFFECTS + METHODS TO OVERCOME THEM:

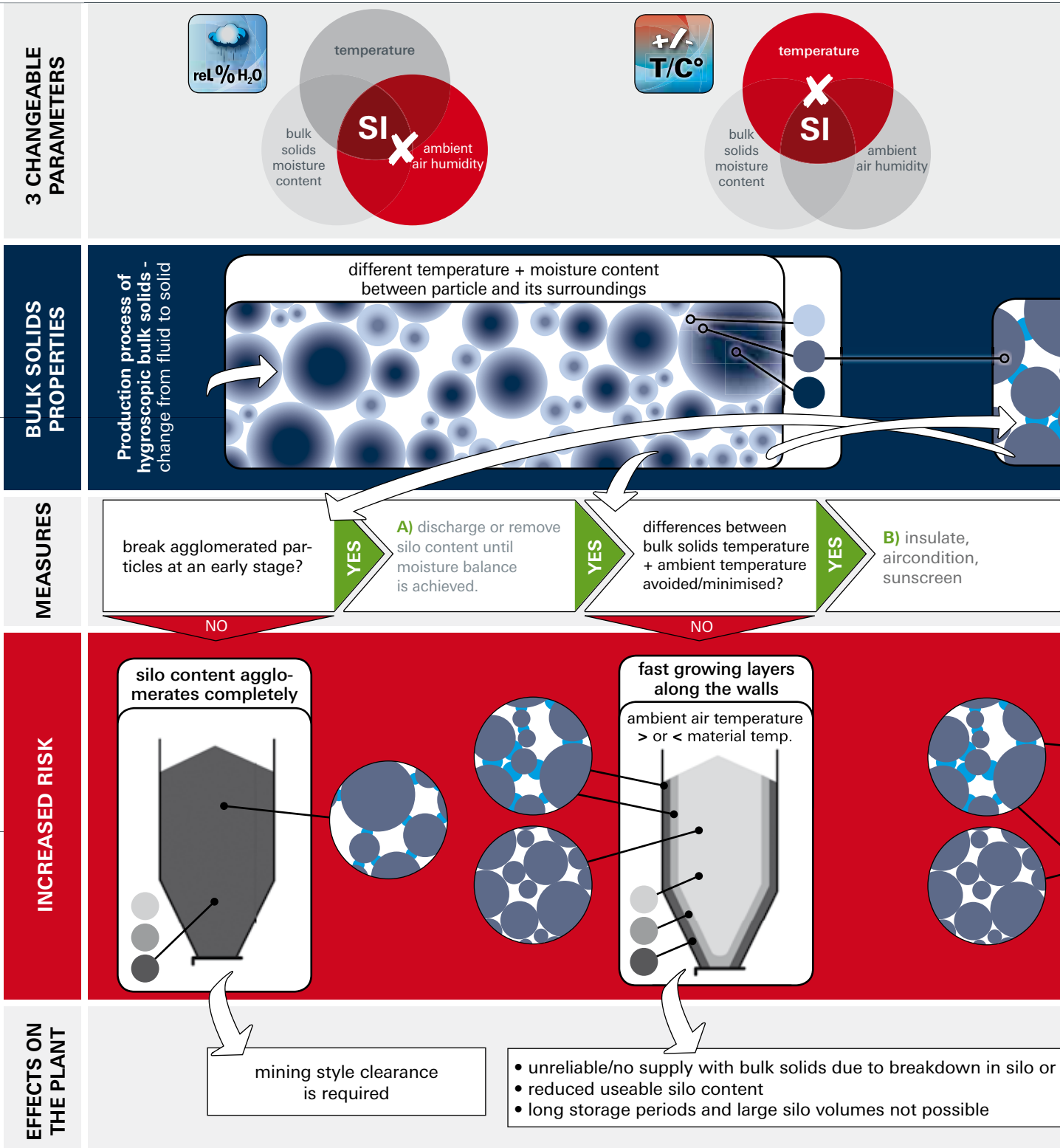

**Legend:**  
moisture scale



rigidity scale



AIM ↓

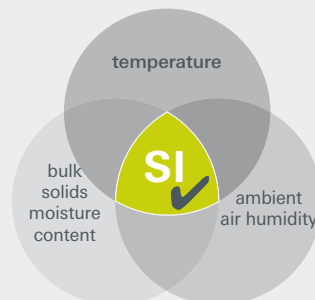
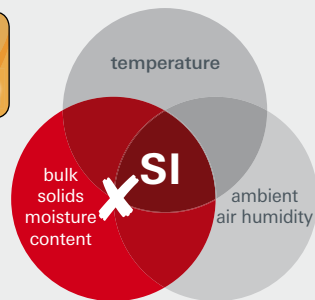
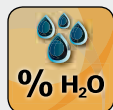

**CONDITIONING:**

By conditioning hygroscopic bulk solids with techniques such as coating, prilling or the addition of flow additives, moisture migration can be minimised and consequently the flowability of bulk solids is increased.

In many cases conditioning is not sufficient or not technically or economically viable.

agglomerated particles

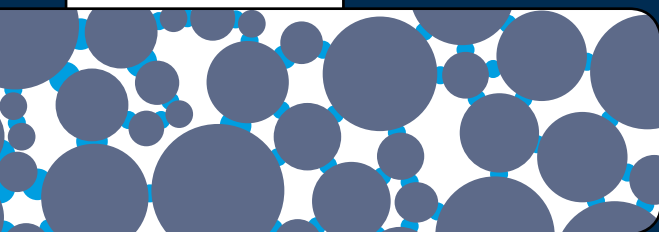

without agglomerates and in moisture balance

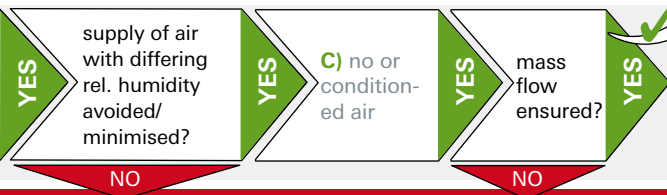
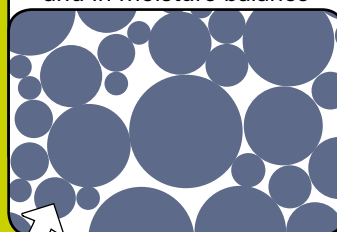

**PROCESS ENGINEERED METHODS**

**A) breaking of agglomerated particles at an early stage**

When hydr. materials come directly out of the production process and physical/chemical procedures have not been completed, an accretion of the silo can only be prevented by discharging or removing the silo content until a moisture balance is achieved.

**B) insulate, aircondition and sunscreen**

To avoid negative influences of an ambient temperature that differs from the bulk solids temperature.

**C) avoid using an air supply that has a different rel. humidity**

No pneumatic loosening and sealing of silo outlet

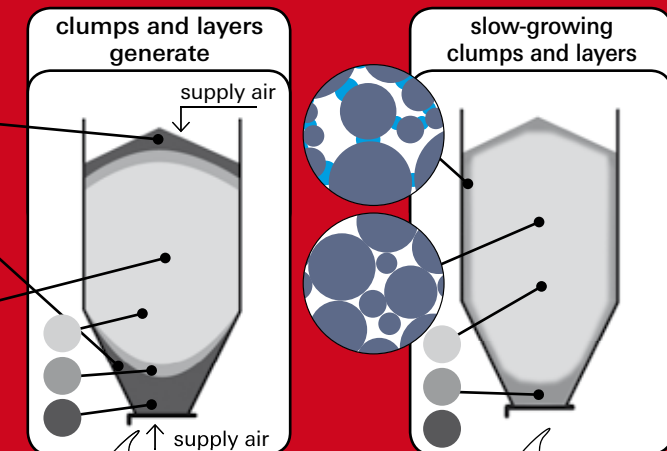

downstreamed metering and conveying systems

efficiently working silo plant even for long storage periods



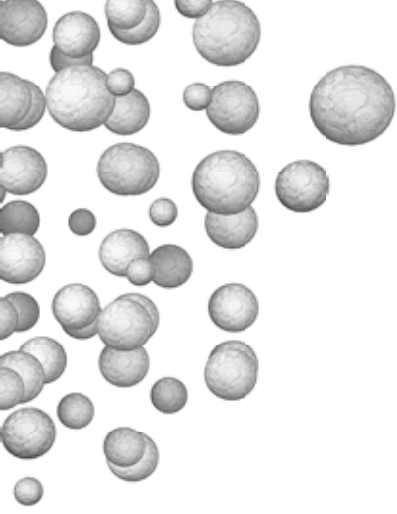

# OSZILLOMAT + MULTIGON ARE THE CORE COMPONENTS TO MANAGE HYGROSCOPIC MATERIALS IN BULK SOLIDS PLANTS.

BULK SOLIDS LOGISTICS PRESENTED AS A STATE OF THE ART SOLUTION FOR CONNECTING PROCESSES.



The automated solution - containing buffers, conveying systems, discharge machines and dosage systems - is determined by input, output and the bulk solids characteristics.

You will no longer be busy checking details; Geroldinger will do this job for you. We offer highly economical and efficient bulk solids plants. Engineering, construction, delivery and assembly are included in our package. One plant - one turnkey solution. Our formula for success says:

**„It is essential to convey the right quantity of bulk solids in perfect quality at the very right moment to the next process!“**

## MULTIGON

The patented **MULTIGON** silo system is the preferred choice for hygroscopic materials. The most evident difference to conventional round silos is the octagonal cross section. Very special benefits of the **MULTIGON** silo are:

- the outstanding insulation value, which prevents/minimises condensation
- smooth internal silo walls, which prevent layers from forming
- the use of premium stainless steel is considerably cheaper than when used for round silos

## OSZILLOMAT

The **OSZILLOMAT** system is able to discharge the bulk solids equally over the whole outlet cross-section. The oscillating beams enforce mass flow, all zones inside the silo are in movement. In addition, an accretion or bridge building are avoided. At the same time layers and clumps are crushed, **without breaking the individual bulk solids particles**. The downstream processes are prevented from damage and subsequent processes are fed reliably and precisely! **Fully automated!**



In France a 50 m<sup>3</sup> round silo for pharmaceutical salt as well as an **OSZILLOMAT** discharge system and a pneum. dense phase conveyor incl. pressure vessel with a volume of 200 l has been implemented.

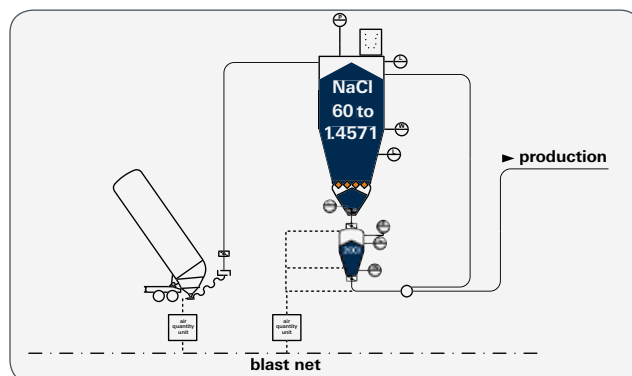

# OUR INTERNATIONAL REFERENCES IN THE HYGROSCOPIC BULK SOLIDS FIELD.



In Germany a 2250 m<sup>3</sup> **MULTIGON** silo for urea and melamine as well as an **OSZILLOMAT** discharge system and a pneumatic conveyor has been implemented.

The project – an investment of 2.5 mill. euros – was implemented for a flake board manufacturer. The flow was realised, based on the delivery by rail and truck, as well as on the time-/quantity profile at the input to two reactors for resin production and to four reactors for glue production. The latter demanded some additional special requirements for dosing.

Urea storage: space-saving **MULTIGON** silos were built. The mass flow of the hygroscopic materials was provided by special flow profiles and the **OSZILLOMAT** discharge system which was developed specially for complex substances.

The solution: pneumatic + mechanical conveyor systems, rectangular bins for buffering both melamine and urea, a discharge system including a dosage and weighing system, as well as the entire control system, which was integrated into an already existing system.

### References by product:

- urea
- sugar
- fertiliser
- nitrates
- NaCl
- FeSO<sub>4</sub>
- phosphates
- oxalic acid
- and many more

### References by industrial sector:

- chemical industry
- stones/earth
- wood industry
- foodstuffs ind.
- pharma. ind.
- and many more

### References by country:

- Germany
- Austria
- Poland
- Russia
- Czech Republic
- and many more

In Denmark a 160 m<sup>3</sup> **MULTIGON** silo for urea as well as an **OSZILLOMAT** discharge system and a pneumatic conveyor were implemented.

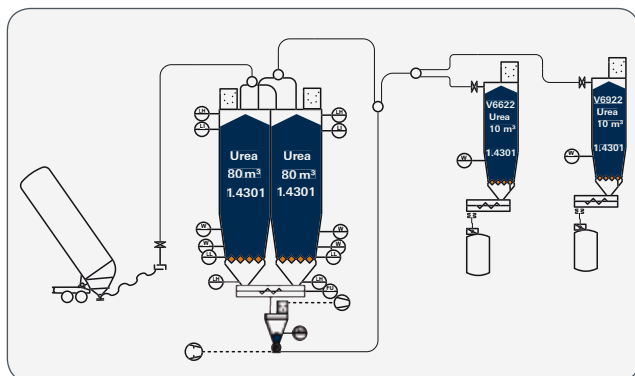

● "Earlier we had to handle Urea in Big Bags. As a pharmaceutical plant it is important for us to produce within enclosed units, mainly to avoid foreign particles in our products. Oszillomat made this possible for Urea due to reliable discharge. Furthermore, the unit does a great job of dosing. Meanwhile we extended our plant in Norway with further Oszillomat machinery and also equipped our facility in Denmark."

**Henrik Fismen,**  
Plant Development Manager,  
Pronova BioPharma Norge AS

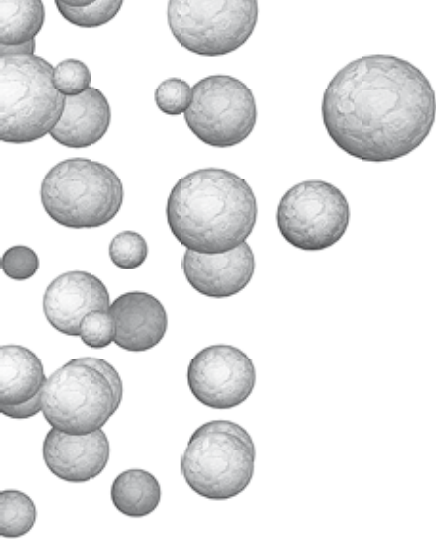

**Consultation**  
**Research + Engineering**  
**Production & Assembly**  
 Turnkey Systems  
 from planning to start-up

**Storage**  
 Mass flow silos:  
 Round + octagonal  
**MULTIGON**

**Conveyor Systems**  
 Pneumatic conveyor systems,  
 screw conveyors,  
 chain conveyors

**Discharging, mixing**  
**Dosing + weighing**  
 Systems for mass flows:  
**OSZILLOMAT**, screw conveyors

**Process Automation**  
 Controlling, recording,  
 visualizing

HYGROSCOPIC

## GEROLDINGER'S TURNKEY BULK SOLIDS PLANTS – THE EFFICIENT „ALL IN ONE“ PACKAGE.

From engineering to assembly.  
 From simple materials to complex bulk solids and sophisticated applications.

Feel free to test us!

Please contact our professional staff members for further information:

**INFO-LINE: +43 7766 2437-380.**

You will also find more detailed information at [www.geroldinger.com](http://www.geroldinger.com).

## FURTHER INFORMATION MATERIAL

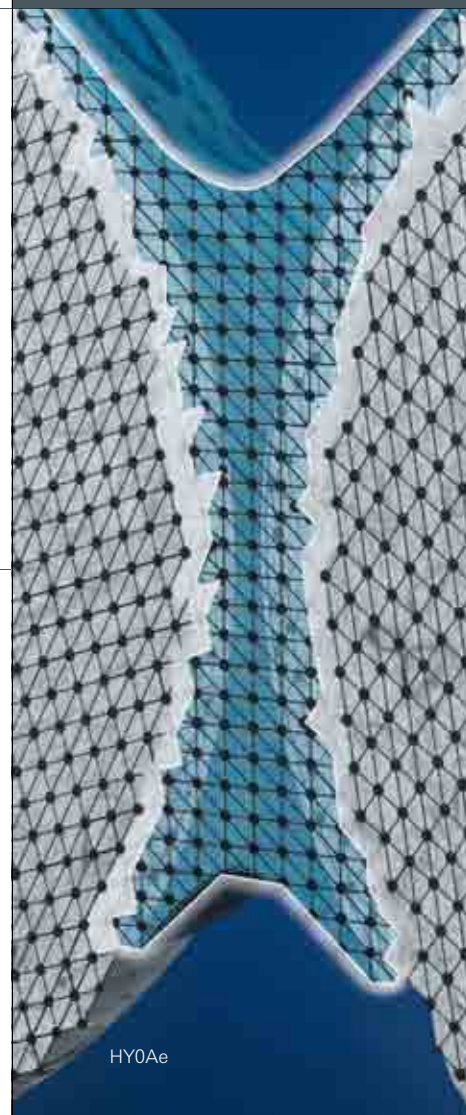

GEROLDINGER GMBH  
 Au-Straße 9, 4771 Sigharting, Austria  
 T: +43 7766 2437, F: +43 7766 2437 - 24, [office@geroldinger.com](mailto:office@geroldinger.com)

HY0Ae

[geroldinger.com](http://geroldinger.com)