

Piston Pumps

Paste and Thickened Tailings



Schwing Bioset Pump Technology

Hydraulically Driven Piston Pumps



Fields of Application:

- Underground Paste Backfill
- Surface Tailings Disposal
- Oil Sands Tailings
- Mining Slimes
- Coal Slurries
- Grout
- Fly Ashes
- Dredging Spoils
- Inorganic Slurries 80+% DS Content
- FGD / Gypsum Slurries

Comprehensive Material Handling Solutions

The Schwing *Advantage*

Schwing has over five decades of experience with self priming positive displacement piston pumps for transporting abrasive slurries and pastes. Originally designed for the rigors of pumping concrete, these hydraulically actuated pumps have been adapted to transport virtually everything that could be fed into them over the years. Equipped with either electric or diesel drives and controlled by local PLC or remote SCADA systems, Schwing pioneered the use of piston pumps for hard to handle materials.

Hundreds of successful installations in the harshest operating conditions on the planet speak to the durability of Schwing piston pumps. All hydraulic switching, open loop hydraulics, electronic power control, and soft-switching are just some of the features found standard only on Schwing piston pumps.

Five decades later the Schwing *Advantage* is still going strong as we continually pioneer new technology and new features to improve our piston pump technology. Our R&D efforts have led to numerous proprietary features found exclusively on Schwing pumps that provide our Customers with top of the line performance and monitoring capabilities. Features like run-dry

protection, flow measurement systems, and hydraulic ideal control circuit technology are only found on Schwing pumps.

At Schwing Biosoet we don't just want your business; we want your complete satisfaction and success. This respect of your bottom line has led Schwing Biosoet to develop an after-market support program for our North American manufacturing that is a hallmark in the industry. A comprehensive inventory of spare parts stocked in our warehouse, a team of field service technicians averaging over 10 years of experience, annual Service Schools utilizing the latest in computerized training techniques and cutaway components and interactive CD's, and customer support personnel to help troubleshoot your system over the phone-all of this based at our factory in Somerset, WI, and all of this to keep your operation running smoothly.

We look forward to welcoming your firm to our long list of satisfied customers. Call one of our representatives today and learn more about the Schwing Biosoet *Advantage*.



Pump Features



Dual Discharge

Poppet valves with dual discharges allow grout to be easily pumped to multiple injection points within the tunnel annulus. Optionally, each cylinder can be independently controlled such that each operates at differing speeds. Discharges are in-line with the pump and do not create high pressure wear points by making 90 degree turns within the discharge valve.



Horizontal/Vertical Configuration

Schwing Bioset pumps can be configured in either vertical or horizontal planes. This flexibility allows Schwing Bioset pumps to accommodate virtually any feed system or upstream equipment configuration possible.

Pressure and Capacity

Schwing Bioset's current capabilities allow operating pressures up to 201 bar (2,915 psi) and flow rates up to 1,130 m³/hr (5,000 gpm). These impressive machines can handle virtually anything you can dish out, and with Schwing Bioset's unwavering commitment to continually develop and improve our pumps, there is a good chance these values are even higher today!

PUMP MODEL	KSP 50	KSP 65	KSP 80	KSP 110	KSP 120
Pump Cylinder Capacity (GAL/L)	13.3/50	17/65	22/80	29.8/110	33.5/120
Pump Cylinder Diameter (INCH/MM)	7.9/200	9.1/230	9.1/230	11.8/300	9.8/250
Stroke Length (INCH/MM)	63/1,600	63/1,600	78.7/2,000	63/1,600	98.4/2,500
Hydraulic Cylinder Diameter (INCH/MM)	5.9/150	5.9/150	5.9/150	7.8/200	4.9/125
Cylinder Ratio	1.78	2.35	2.35	2.25	4.34
Overall Length (INCH/MM)	215/5,461	215/5,461	250/6,350	215/5,461	285/7,215
Approx. Weight - Large Poppet (LB/KG)	5,750/2,615	6,000/2,730	6,230/2,830	6,750/3,070	NA
Approx. Weight - XL Poppet (LB/KG)	10,915/4,960	11,165/5,075	11,460/5,210	11,915/5,415	NA
Approx. Weight - Rock Valve (LB/KG)	7,250/3,300	7,500/3,410	7,730/3,510	9,250/3,750	7,000/3,180
Large Poppet Suction Diameter (INCH/MM)	8.3/210	8.3/210	8.3/210	8.3/210	NA
Large Poppet Pressure Diameter (INCH/MM)	5.9/150	5.9/150	5.9/150	5.9/150	NA
XL Poppet Suction Diameter (INCH/MM)	11.0/280	11.0/280	11.0/280	11.0/280	NA
XL Poppet Pressure Diameter (INCH/MM)	9.8/250	9.8/250	9.8/250	9.8/250	NA
Pressure Rating with Large Poppet (PSI/BAR)	1,500/104	1,500/104	1,500/104	1,500/104	NA
Pressure Rating with Poppet (PSI/BAR)	1,885/130	1,885/130	1,885/130	1,885/130	NA
Pressure Rating with Rock Valve (PSI/BAR)	2,915/201	2,360/163	N/A	1,450/100	1,160/80

continued >



Hydraulic Switching

Whether it is exposure to moisture, corrosive elements, weather elements, or other challenging conditions, Schwing Bioset pumps are located in some of the harshest working environments on the planet; it is these environments where electronic devices tend to be the first to fail. For this reason all Schwing Bioset pumps are built with hydraulic switching as a standard feature.

Open Loop Hydraulics

Schwing Bioset offers open loop hydraulics which are more efficient than closed loop systems. Open loops require fewer kW for operations, afford greater oil filtration efficiency, impart less stress on the hydraulic oil resulting in longer service life, and less complex requiring fewer hydraulic circuits.

PUMP MODEL	KSP 140	KSP 220	KSP 315	KSP 1260	KSP 1890
Pump Cylinder Capacity (GAL/L)	37.5/140	57.9/220	83/315	83/315	83/315
Pump Cylinder Diameter (INCH/MM)	11.8/300	11.8/300	14.2/360	14.2/360	14.2/360
Stroke Length (INCH/MM)	78.7/2,000	122/3,100	122/3,100	122/3,100	122/3,100
Hydraulic Cylinder Diameter (INCH/MM)	7.8/200	7.8/200	9.8/250	9.8/250	9.8/250
Cylinder Ratio	2.25	2.25	2.07	2.07	2.07
Overall Length (INCH/MM)	250/6,350	374/9,500	390/9,906	390/9,906	390/9,906
Approx. Weight - Large Poppet (LB/KG)	9,500/4,320	11,480/5,220	NA	NA	NA
Approx. Weight - XL Poppet (LB/KG)	13,900/6,320	15,880/7,220	35,300/16,000	35,300/16,000	35,300/16,000
Approx. Weight - Rock Valve (LB/KG)	11,000/5,000	12,980/5,900	NA	NA	NA
Large Poppet Suction Diameter (INCH/MM)	8.3/210	8.3/210	8.3/210	8.3/210	8.3/210
Large Poppet Pressure Diameter (INCH/MM)	5.9/150	5.9/150	5.9/150	5.9/150	5.9/150
XL Poppet Suction Diameter (INCH/MM)	11.0/280	11.0/280	11.0/280	11.0/280	11.0/280
XL Poppet Pressure Diameter (INCH/MM)	9.8/250	9.8/250	9.8/250	9.8/250	9.8/250
Pressure Rating with Large Poppet (PSI/BAR)	1,625/112	1,625/112	1,625/112	1,625/112	1,625/112
Pressure Rating with Poppet (PSI/BAR)	1,885/130	1,885/130	1,885/130	1,885/130	1,885/130
Pressure Rating with Rock Valve (PSI/BAR)	1,450/100	1,450/100	NA	NA	NA

Piston Pump Pump Technology

Your Task - Our Consultation - The Solution



Run-Dry Protection

Schwing Bioaset's proprietary Run-Dry protection allows the PLC to continuously monitor pump operating conditions and alert operating staff when pump starvation or cavitation occurs. This will help prevent unplanned shut-downs and lost production time that will cost your operation real money.

Flow Measurement System

Schwing Bioaset's patented flow measurement system measures the volume of material pumped within 5% and instantaneously reports the filling efficiency of the material cylinders providing real-time monitoring of the health of your pump. This information is used by operating staff to precisely control operations and schedule wear part replacement on their schedule, rather than reacting to any unexpected shut-downs. Schwing Bioaset's Flow Measurement System is just another example of how our industry leading technology plays a key role in your operations success.

CPR Poppet Wear Parts

Two versions of poppet valve disc and seat wear parts are available. Standard parts are case hardened to HR_c55 and they are suitable for most applications. For high pressure and highly abrasive applications a proprietary CPR alloy that offers extended life is available. This CPR alloy contains a high content of chromium and tungsten and has a hardness ranging from 60-64 HR_c.



SCHWING BIOSET FLOW MEASURING SYSTEM



Your Task - Our Consultation - The Solution

Poppet Valve

Applications: Compressible material, filter cakes, slurries, tailings, pastes.



Rock Valve

Application: incompressible material with coarse and foreign particles up to 3" in diameter.

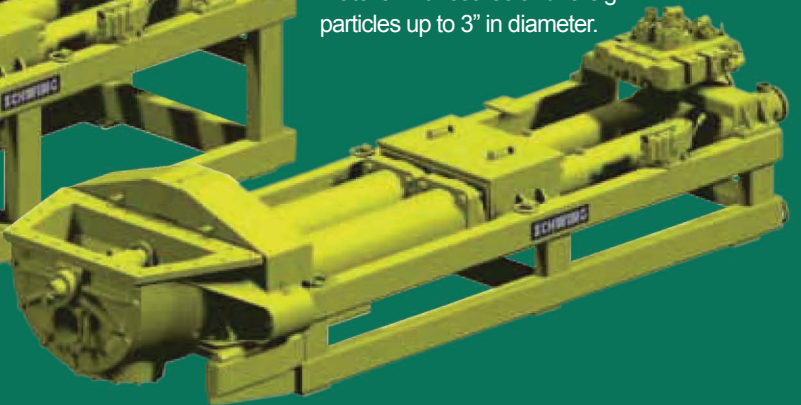

Ideal Control Circuit (ICC)

Ideal Control Circuit technology decreases the velocity of the material in the pipeline at the end of pumping strokes and ramps back up to operational speed at the beginning of each stroke. This gradual deceleration and acceleration cushions the material flow on every stroke and eliminates water-hammer in the pipeline caused by abrupt changes in material velocity. Poppet shifting speeds are also controlled by the ICC to extend their wear life.

Electronic Power Control (EPC)

Electronic Power Control automatically reduces pump capacity and re-allocates available horsepower for higher pressure operations. This allows off-spec material to be pumped out of the pipeline at lower production rates rather than shutting down and potentially sacrificing hundreds of meters of pipeline.

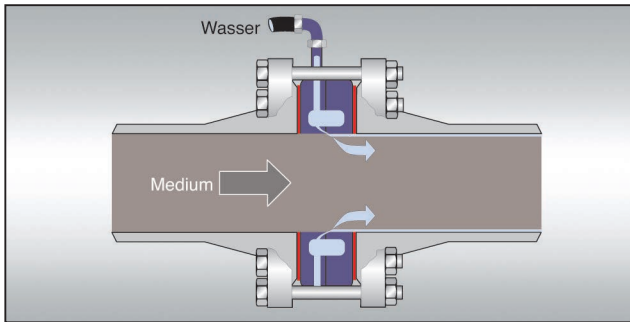

Pipeline Lubrication

The length of pipe and the friction resistance of the pumped medium at the pipe wall determined the pumping pressure required. With the use of a pipeline lubrication system the pressure can be reduced at times by more than 50% simply by adding a thin film of water to the pipe wall.

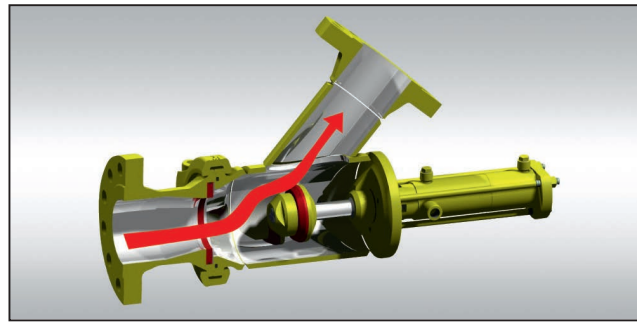

Sequence Control Valve

The hydraulically actuated sequence valves ensure optimal material distribution to multiple destinations. Standard poppet valve components are used in all sequence valves.

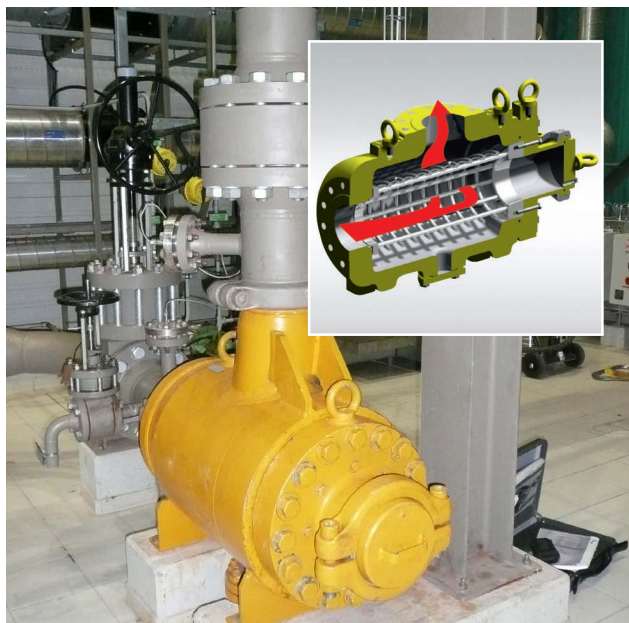

Reject Separator / Stone Trap

Coarse material larger than the mesh width of the screening basket is retained and the downstream equipment is protected from possible damage from the off-spec material.

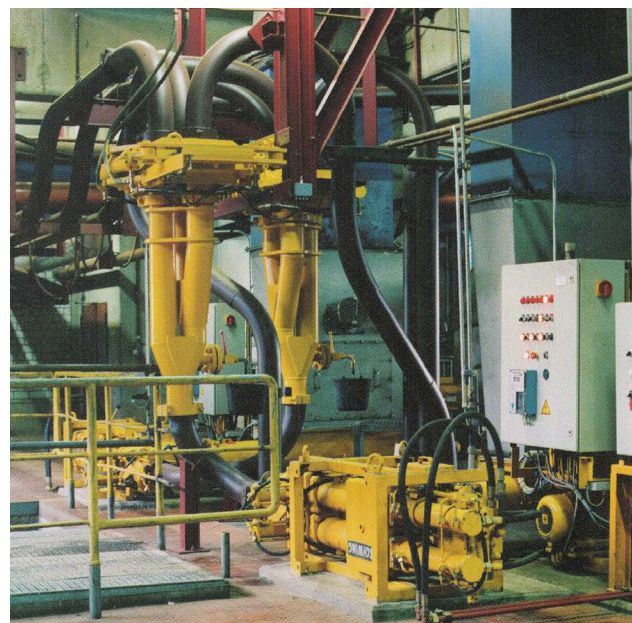

Three-Way Switch

Hydraulically actuated three-way switches allow material flow to be changed between multiple destinations such as boilers, truck loading facilities, or ponds, with ease.

After Market Maintenance and Repair

Support Beyond Installation



Pumping pistons are available in BUNA-N and Viton construction to accommodate various pumping media. Large pistons are available in modular assemblies to reduce the size and weight of individual pieces to simplify maintenance procedures.



Rock valve wear parts are available in standard case hardened or carbide construction for high pressure and highly abrasive applications to maximize service lives.



Poppet valve disc and seat components are available in case hardened steel or a proprietary CPR alloy with HRC up to 64.

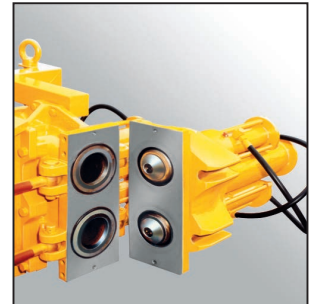

Poppet valve housing is equipped with hinges that allow the casting to be easily opened to provide convenient access to the poppet valve wear parts.

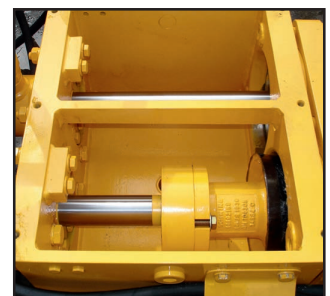
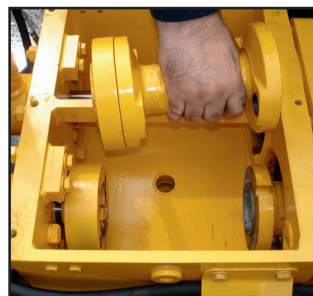
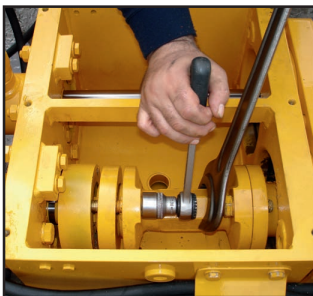

Replacement of the pumping piston is performed by removing the bolts and then the extension piece between the hydraulic cylinder and pumping piston. Once this piece is removed the hydraulic cylinder is extended and one bolt is replaced to allow for removal of the pumping piston. The new piston is installed by reversing this procedure.

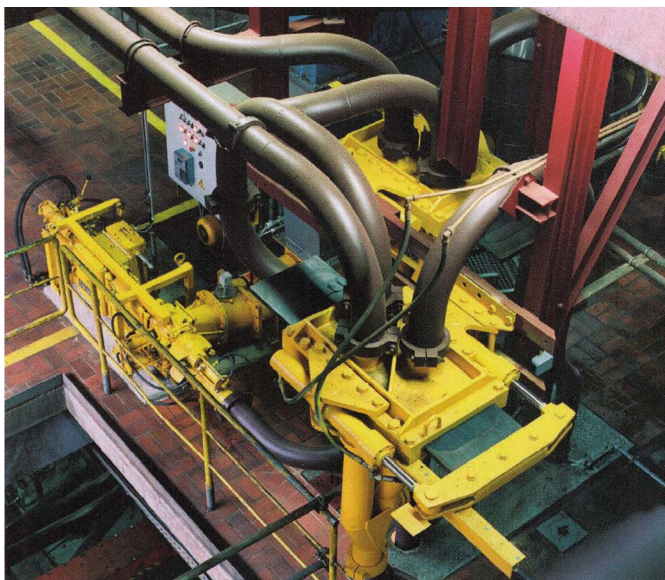

Piping Systems

When your severe duty application requires a severe duty pipe system, Schwing Bioiset's proprietary Diamond Series pipe is up to the task. Heat treated from the inside out to allow welded connections while providing an interior surface that is up to 65HRC; SVI's Diamond Series pipe combines performance and workability all in one. Couple this pipe to our Dual-Seal high pressure couplings, designed such that the joints tighten as pressure increases, these zero-leak wonder couplings prove to our customers that even the toughest applications aren't so tough after all. Schwing Bioiset offers complete piping systems including design and supply of piping, laterals, tees, wyes, custom fittings, couplings, supports, sequencing valves, ball valves, and three way switches.

A Name You Can Trust

Screw Press Dewatering



SBI's Screw Press provides excellent dewatering capabilities with a system that is virtually maintenance free, and can be run unattended.

Fluid Bed Dryer



Schwing Bioaset's fluid bed dryer offers a thermally efficient means of producing dust-free Class A biosolids. The automated system allows for unattended operation, and produces a very simple product to store, transport, and apply.

Operating & Marketing Services



Schwing Bioaset's partnership with Biosolids Distribution Services Inc. creates the unique ability to offer complete handling solutions with engineering, equipment, and distribution of Class A biosolids, responsibly offered by a single provider.

Sliding Frame



Sliding frame systems, whether used as truck receiving, truck loading, or as intermediate storage, offer a flexible means of storing dewatered solids while eliminating bridging. The flexible design allows for various process requirements.

Nutrient Recovery & Struvite Harvesting



Schwing Bioaset's nutrient removal system recovers Ortho-Phosphate and Ammonia Nitrogen from wastewater as struvite, reducing phosphorus loads, preventing plant fouling, and creating a valuable end product.

Bioaset Process



Schwing Bioaset offers the Bioaset lime stabilization process, which is approved to EPA's 503 regulations. The Bioaset process provides municipalities a low cost Class A system that is affordable to operate and easy to maintain.

Contact Information

Wisconsin:

350 SMC Drive
Somerset, WI 54025
TEL 715-247-3433
FAX 715-247-3438

www.schwingbioset.com

Connecticut:

98 Mill Plain Ste. 2B
Danbury, CT 06811
TEL 203-744-2100
FAX 203-744-2837



Printed on Recycled Paper